

# SPECIFICATIONS

## Bungalow

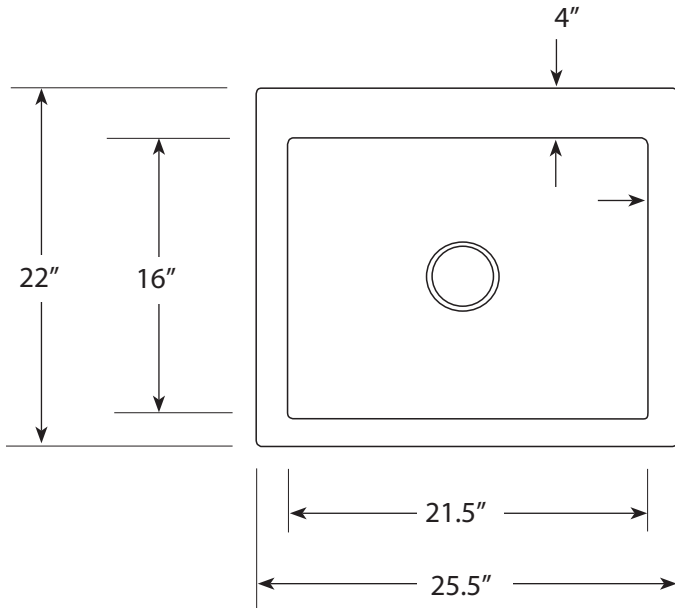

← 2" CPS270- Antique  
CPS570- Brushed Nickel

### PRODUCT DETAILS

- \* 25.5" x 22" x 10" OD
- \* 21.5" x 16" x 9.5" ID
- \* Hand hammered 16 gauge recycled copper
- \* Apron extends 3.5" on sides
- \* 3.5" drain opening
- \* Dimensions are not exact and may vary  $\pm 1/2"$

### INSTALLATION

- \* Undermount

### COORDINATING PRODUCTS

- \* Drains: DR320 or DR340
- \* Bottom Grid: GR970

### STANDARDS COMPLIANCE

- \* IAPMO Listed / cUPC

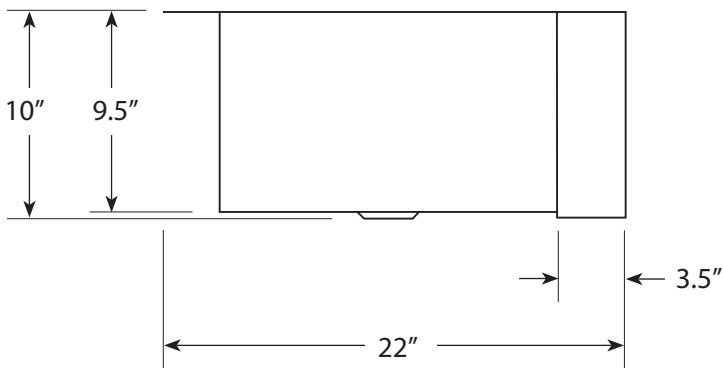

### IMPORTANT

Due to the handcrafted nature of this product, it will vary in finish, texture, hammering, and other details. Dimensions may vary up to 1/2". We strongly recommend that you wait for the actual product before making any installation cuts.